

E15 PRESS RELEASE

**E15 AT IMM COLOGNE, HALL 11.2, STAND J20
COLOGNE, 17 – 23 JANUARY 2011**

E15 DEBUTS ITS COLLECTION OF NEW RELEASES FROM APRIL AND OCTOBER 2010 IN COLOGNE AT IMM COLOGNE 2011. THE GERMAN PREMIUM BRAND PRESENTS SEATING FURNITURE BY DESIGNER STEFAN DIEZ, TABLES BY ARCHITECT PHILIPP MAINZER, INSPIRING FABRICS FOR ITS UPHOLSTERED FURNITURE COLLECTION AND EXUBERANT NEW COLOURS FOR ITS CARPET CP03 KAVIR BY FARAH EBRAHIMI.

With a gallery-style presentation e15 debuts in Cologne the new lounge chairs EC03 EUGENE and EC02 BESSY, the bar stool ST10 JEAN and the sofa SF05 BESS by designer Stefan Diez. On show are also the two new solid oak dining and conference tables TA17 LONDON and TA18 ZEHN and the glass side table CT08 VIER by e15's creative director Philipp Mainzer. An eclectic new fabric selection for its upholstered furniture and exuberant new colours by designer Farah Ebrahimi for the carpet CP03 KAVIR are additional product highlights. In addition, e15 will present for the first time at a furniture fair its new design object MUNKEN CUBE.

The German brand e15 stands for modern design, high grade materials and innovative, handcraft production methods. The 2010 collection, launched in April and October, emphasises these principles. The new seating furniture by designer Stefan Diez is the development of the dynamic chair family CH04 HOUDINI. Both new tables by Philipp Mainzer on show at IMM Cologne reflect the pure and bold e15 design language of modern, sensuously refined, enduring furniture whilst stimulating and complementing organic forms of the Houdini family by Stefan Diez. Together thus establishing an iconic combination of tables and chairs by e15.

Following its anniversary year presentation last year, e15 starts into 2011 with a fresh exhibition design. In a black room, the products are elevated onto white platforms and cubes of different heights, accentuating the aesthetic form of the design. Their elevation also results in a different angle of vision onto the products, allowing a detailed view of the construction and design. E15's new exhibition design has its debut at IMM Cologne 2011 in January and offers an outlook on the German brand's presentation style in 2011 and a first glimpse of e15's plans for this year.

NEW SEATING FURNITURE BY DESIGNER STEFAN DIEZ

With e15's chair family CH04 HOUDINI by Stefan Diez, the German brand brought to life a new material and form language for chairs in 2009, which has already received international recognition being awarded the Red Dot Best of Best Design Award 2010 and the Interior Innovation Award 2010. From the continuation of this creative collaboration with Stefan Diez, e15 in April 2010 presented a new family of seating furniture, which is in its unique form and material a direct development of the CH04 HOUDINI. With the sofa SF05 BESS, the small lounge chair and stool EC02 BESSY, the lounge chair EC03 EUGENE as well as the bar stool ST10 JEAN, e15 presents seating items that are modern and enduring in appearance, deceptively strong and light in technique, which suit diverse interiors as either individual pieces or in combination with other e15 furniture. All new seating products are available in the CH04 HOUDINI colours, signal white, traffic grey, jet black and clear lacquered oak.

/ more..

THE STOOL ST10 JEAN AND LOUNGE CHAIR EC03 EUGENE

At IMM Cologne 2011 e15 showcases for the first time in Cologne the new bar stool ST10 JEAN and the lounge chair EC03 EUGENE. Based on the innovative bent construction of the chair CH04 HOUDINI both new pieces draw on form details of the chair. Made from oak veneered plywood sheets, which are bent by hand around a milled solid wood base, the bar stool ST10 JEAN consists of a seat with circumferential brim, which provides comfort when seated. Only between the front two legs runs a cross beam with an embedded steel profile, which acts as a foot rest and gives the stool stability. Available in two different heights, ST10 JEAN is suitable for contract as well as private use at a kitchen counter. Upholstery of the seat is possible.

The generously proportioned lounge chair EC03 EUGENE exudes lightness and leisure with its high back, wide, deep seat shell and sloped back legs and presents the modern interpretation of a classic lounge chair. Also made from flexible oak veneered lacquered plywood, the lounge chair with its round bent wooden back offers ample comfort without padding. For additional comfort and style, the versatile lounge chair can be complemented with the seat and head cushions CU06 NIMA, CU09 EUGENE S and CU10 EUGENE H. Fixed upholstery of the seat is also possible.

THE SOFA SF05 BESS AND THE SMALL LOUNGE CHAIR AND STOOL EC02 BESSY

The sofa SF05 BESS and the small lounge chair and stool EC02 BESSY are also new releases first presented at Salone del Mobile 2010 and exhibited at IMM Cologne 2011. As part of the new seating furniture family by Stefan Diez, the upholstered sofa and lounge chair and stool from flexible oak veneered, lacquered plywood are the idyllic development of the chair family CH04 HOUDINI. With its comfortable angled high back and round removable upholstered seat, the lounge chair EC02 BESSY, reminiscent of cocktail-lounger, is space-saving and thus is suitable for private as well as public interiors, especially in hotel lobbies and bars. For greater comfort and style, the lounge chair can be complemented with the CU06 NIMA cushion. Optionally, EC02 BESSY is also available as a stool without back rest.

The sofa SF05 BESS is an innovative two-seater with an upholstered seat. With its graceful bent backrest from flexible oak-veneered plywood, the new sofa takes up the design language of the chair CH04 HOUDINI. With its two available seating-depths, the sofa is well suited for private and contract interiors. The removable high grade upholstery is supplemented with a base of NOSAG-springs built into the sofa and a well-balanced combination of foamed materials. For additional comfort and style the sofa SF05 BESS can be beautifully complemented with various sizes of the cushion CU06 NIMA.

NEW RELEASES BY E15 CREATIVE DIRECTOR PHILIPP MAINZER

DINING TABLE TA17 LONDON

As an evolution of the classic TA04 BIGFOOT™ e15 showcases the new table TA17 LONDON at IMM Cologne. The legs and table top each have an impressive solid wood thickness of 60 mm which exude strength and modernity resulting in a pleasing and calm harmony of the proportions. TA17 LONDON by architect Philipp Mainzer takes up the design language of the 1995 classic. Compared to the BIGFOOT™ table, TA17 LONDON is designed without a frame and the cracks in the table's legs are filled, which add to the table's refined appearance. TA17 LONDON with its rectangular, length-wise positioned legs establishes its own powerful design language while preserving a graceful evolution of the classic TA04 BIGFOOT™.

/ more..

THE TABLE TA18 ZEHN

Awarded with the Interior Innovation Award 2011, the conference and dining table TA18 ZEHN is the latest table from e15. Through the complete reduction to its symmetric form, TA18 ZEHN has a sculptural appearance and is thus completely in line with the e15 design language. Due to its simple middle leg, which dependant on the length of the table, is symmetrically or asymmetrically positioned underneath the table top, the usual protruding stilts are omitted. The table's different lengths thus offer different overall appearances. Available in oiled European oak and with a solid wood thickness of 40 mm, the table TA18 ZEHN with its reduced form is suitable for many interiors. With a length of 2400 mm TA18 offers seating for up to eight people and for up to ten people with a length of 3000 mm.

GLASS SIDE TABLE CT08 VIER

The glass table CT08 VIER represents the consequential development of the glass side table CT07 DREI. Made from five coloured glass slabs joined together, the table designed by Philipp Mainzer extends the e15 range of side tables complementing the sofa system SF03 SHIRAZ. Due to its symmetric geometry, the table in dark blue or smoke grey solid coloured glass appears as a smart and stylish object which can serve as a side table, storage unit, bedside table or newspaper stand.

NEW COLOURS FOR THE CARPET CP03 KAVIR BY FARAH EBRAHIMI

In a desire to introduce colour in modern and flexible ways to live with, designer Farah Ebrahimi re-introduces the CP03 KAVIR carpet for e15 in seven new shades, extending the current range of light to dark grey. New distinct colours present a modern and exuberant reinterpretation of the traditionally knotted Persian carpet. The CP03 KAVIR is handmade according to traditional methods. The fringe detail becomes more than just a design element, as it respectfully reveals the hand-woven framework of the carpet.

CP03 KAVIR is now available in antique pink with a coral red fringe, zinc yellow joins a fawn brown fringe, 'French salon' shade of pale mint is contrasted with a turquoise blue fringe, the perfect shade of taupe is accented with a mustard coloured fringe, calm ocean blue is joined with an emerald fringe, hunter green is accented with an espresso brown fringe and sapphire blue is contrasted with a violet fringe.

MUNKEN CUBE

The Munken Cube, also awarded with the Interior Innovation Award 2011, is a unique object of paper and wood and is a successful cooperation between e15 and the Swedish manufacturer of natural paper, Arctic Paper. 2200 sheets of high quality, 120 g Munken paper sit on a 60 mm thick solid wood base by e15. The dimensions and construction of the Munken Cube result in an impressive, shape-able concept furniture as well as intelligent working tool which instigates creativity and the conceptualisation of ideas.

Ends. /

Notes to Editors:

E15 AT IMM COLOGNE 2011

Monday, 17.01.2011, Preview day

Tuesday, 18.01. - Sunday, 23.01.2011

09.00 - 18.00 H

Hall 11.2, Stand J20

Trendshow 2011, Interior Trends 2011

Hall 3.2, Stand A010 / D019

Interior Innovation Award

Nord Boulevard, Hall 7

Koelnmesse

Messeplatz 1

50679 Köln

www.imm-cologne.de

For further press information and high resolution images please contact the e15 inhouse PR team:

Susanne Günther, Tel. +49-(0)6171-9795 25, susanne.guenther@e15.com

Carina Müßen, Tel. +49-(0)6171-9795 23, carina.muessen@e15.com

E15 Design und Distributions GmbH

www.e15.com

E15'S COLLECTION OF NEW RELEASES 2010

EC03 EUGENE

Lounge Chair

Design: Stefan Diez, 2010

The lounge chair EC03 EUGENE makes an inspiring link to the chair family CH04 HOUDINI through its unique appearance and construction. With its high back, wide, deep seat shell and sloped back legs this generously proportioned lounge chair exudes lightness and leisure. Made from flexible oak-veneered lacquered plywood, EC03 EUGENE can be complemented with the seat and head cushions CU06 NIMA, CU09 EUGENE S and CU10 EUGENE H. Due to its round bent wooden back, EC03 EUGENE lounge chair offers ample comfort without padding. Fixed upholstery of the seat is possible. The lounge chair EC03 EUGENE is a versatile and unique item that is ideally suited for private and public interiors. Its seat height is 350 mm (13 7/8 inch), its seating depth 590 mm (23 1/4 inch) and seat width 590 mm (23 1/4 inch). EC03 EUGENE is delivered as one piece.

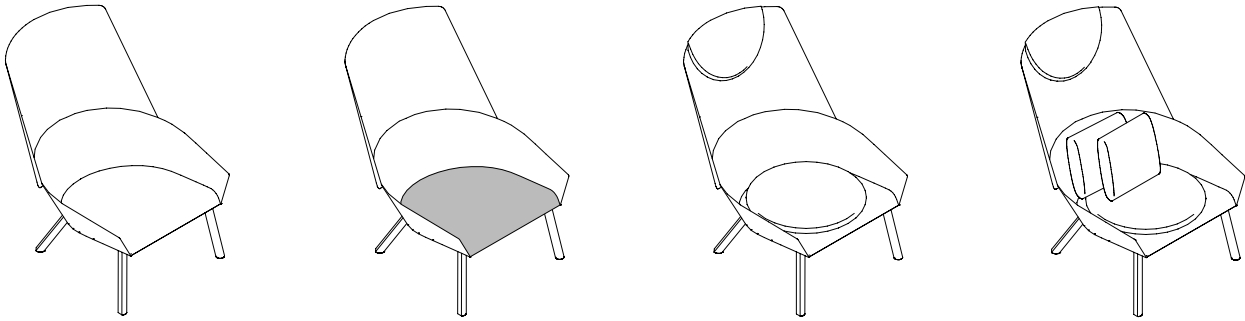

ST10 JEAN

Stool

Design: Stefan Diez, 2010

The bar stool ST10 JEAN is a natural development of the dynamic chair family CH04 HOUDINI. ST10 JEAN consists of a seat with circumferential brim, which provides comfort and hold when seated. Between the front two legs runs a cross beam with an embedded plastic profile, which acts as a foot rest and gives the stool stability. The bar stool ST10 JEAN, made from oak veneered plywood, lacquered, is available in two heights which makes it suitable for contract as well as private use at a kitchen counter. Upholstery of the seat is possible. The bar stool is not stackable and is delivered as one piece.



SF05 BESS

Sofa

Design: Stefan Diez, 2010

The sofa SF05 BESS is an idyllic development of the dynamic construction of the CH04 HOUDINI chair. The two-seater consists of an upholstered seat and a back made from flexible oak-veneered plywood, which is not upholstered. The back is gracefully bent around the back of the seat to form the back rest. The high grade upholstery consists of a body of NO SAG-springs and a well-balanced combination of foamed material. For greater comfort and style, the sofa can be complemented with the cushion CU06 NIMA. With its two different available seating depths, the sofa is well suited for private and contract interiors. SF05 BESS can be beautifully complemented with e15's range of side tables. Its seating height is 400 mm (15 3/4 inch). The two available seating depths are 560 mm (22 inch) and 860 mm (34 inch). The upholstered seat is not fixed. The sofa is delivered as one piece.

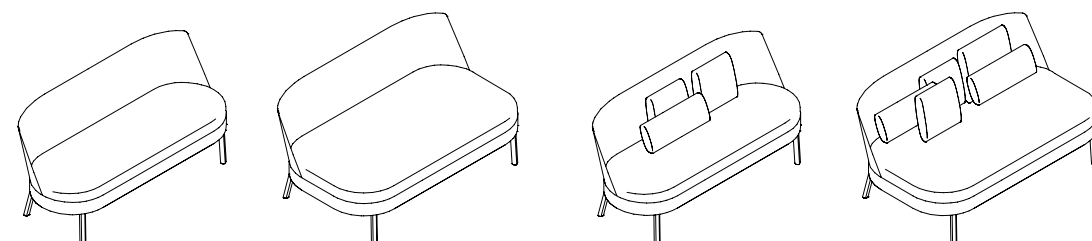

/ more...

EC02 BESSY

Lounge Chair, Stool

Design: Stefan Diez, 2010

The lounge chair EC02 BESSY and the corresponding stool complete the product family around the sofa SF05 BESS. EC02 BESSY has a comfortable high back and round upholstered seat and is made from flexible oak veneered plywood, lacquered. Reminiscent of a cocktail-lounger, the space-saving EC02 BESSY is suitable for private use as well as for contract use especially in hotel lobbies and bars. For more comfort and style, this lounge chair can be complemented with the cushion CU06 NIMA. Optionally, EC02 BESSY is also available as a stool without back rest. EC02 BESSY can be complemented with the sofa SF05 BESS. The seat height is 400 mm (15 3/4 inch) and its seating depths 560 mm (22 inch). The upholstered seat is not fixed. EC02 is delivered as one piece.

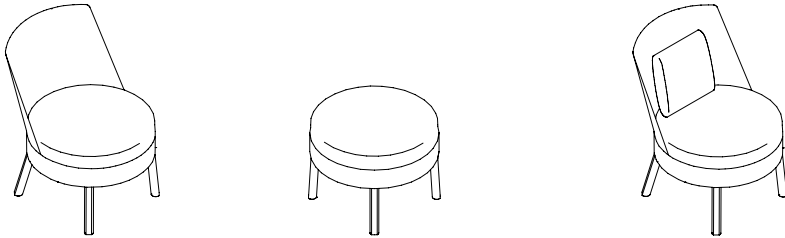

TA17 LONDON

Table

Design: Philipp Mainzer, 2009

As an evolution of the classic TA04 BIGFOOT™ e15 presents the new table TA17 LONDON. The legs and table top each have an impressive solid wood thickness of 60 mm which exude strength and modernity resulting in a pleasing and calm harmony of the proportions. TA17 LONDON by architect Philipp Mainzer takes up the design language of the 1995 classic. Compared to the BIGFOOT™ table, TA17 LONDON is designed without a frame and the cracks in the table's legs are filled, which add to the table's refined appearance. TA17 LONDON with its rectangular, length-wise positioned legs establishes its own powerful design language while preserving a graceful evolution of the classic TA04 BIGFOOT™.

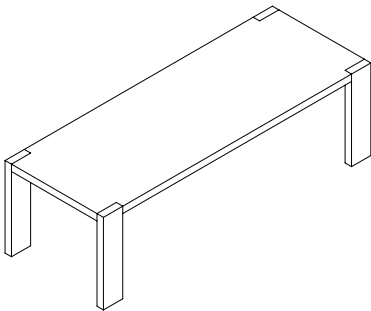

TA18 ZEHN

Table

Design: Philipp Mainzer, 2010

The table TA18 ZEHN has through the complete reduction to its geometric form, a sculptural appearance. Due to its simple middle leg, which dependant on the length of the table, is symmetrically positioned underneath the table top, the usual protruding stilts are omitted. With a solid wood thickness of table top and leg of 40 mm (1 5/8 inch), TA18 ZEHN is available in oiled European oak. Its reduced form enables the table to suit various interiors as a conference or dining table. TA18 ZEHN offers seating for up to eight people with a length of 2400 mm (94 1/2 inch) and up to ten people with a length of 3000 mm (118 1/8 inch). The table TA18 ZEHN is perfectly complemented with the side chair CH04 HOUDINI as well as with the chair CH03 HENNING. The clearance underneath the table top measures 710 mm (28 inch). TA18 ZEHN can be dismantled into four parts.

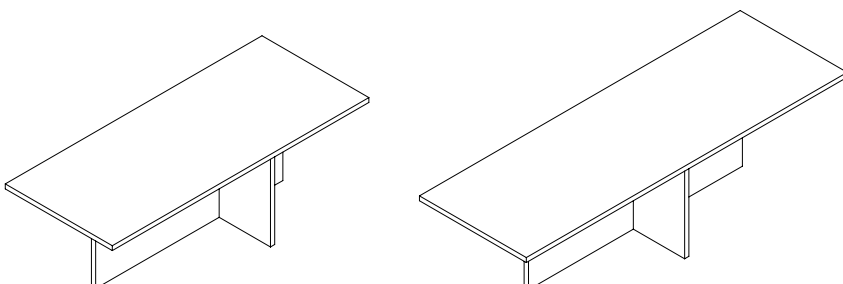

/ more...

CT08 VIER

Side table

Design: Philipp Mainzer, 2009

The glass table CT08 VIER is the latest side table from e15 and represents the consequential development of the glass side table CT07 DREI. Made from five coloured glass slabs joined together, the table designed by Philipp Mainzer extends the e15 range of side tables complementing the sofa system SF03 SHIRAZ. Due to its symmetric geometry, the table in dark blue or smoke grey solid coloured glass appears as a smart and stylish object which can serve as a side table, storage unit, bedside table or newspaper stand.

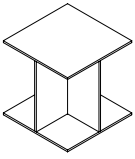

CP03 KAVIR

Carpet

Design: Philipp Mainzer, Farah Ebrahimi 2007 / 2010

With a high density of 80 knots per square inch, the CP03 KAVIR carpet is handmade according to traditional methods. The single-toned surface extends lengthwise into knotted fringes on the sides. The fringe detail becomes more than just a design element, as it reveals the hand-woven framework of all e15 carpets. Like all e15 carpets, the CP03 KAVIR is produced in a socially and environmentally responsible manner by a family-owned business in Nepal without the involvement of child labour.

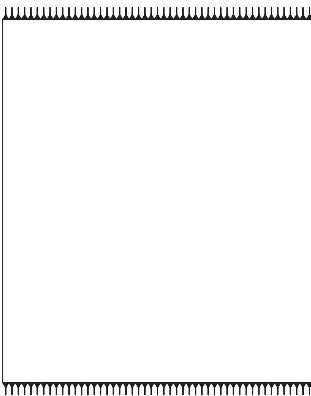

MUNKEN CUBE

With the Munken Cube the German premium furniture design brand e15 and natural paper manufacturer Arctic Paper present a pure yet fascinatingly versatile design object. The Munken Cube is sculpture, working tool and source of inspiration all in one. The form is pure at the same time flexible and consists of a monumental stack of Munken paper and a base of solid oak. From a 6 cm thick solid oak base by e15 "grow" 2200 sheets of high quality 120 g Munken paper to form a 43 cm high pad whose shape can be twisted and deformed. The one-sided glueing of the paper ensures that the Munken Cube retains its form and that every sheet can be detached from the stack.

