

E15 PRESS RELEASE
IMM COLOGNE 2010
COLOGNE, 19. – 24. JANUARY 2010

E15 CELEBRATES ITS 15TH-ANNIVERSARY: THE GERMAN DESIGN BRAND PRESENTS NEW PRODUCTS AT IMM COLOGNE 2010

E15, the German premium furniture brand turns 15. Commencing its anniversary, the company, which started out in 1995 in a workshop in East London, exhibits at imm cologne 2010 with a unique exhibition stand, and launches new products from creative director and co-founder Philipp Mainzer. Makers of the solid wood classics TA04 BIGFOOT™ and ST04 BACKENZAHN™, the company will further show pieces from its 95-product strong interiors collection. The chair family CH04 HOUDINI by Stefan Diez will be presented for the first time in Germany and SH05 ARIE, the shelf by Arik Levy will be showcased in the new dismountable version.

DINING TABLE TA17 LONDON

As an evolution of the classic TA04 BIGFOOT™ e15 presents the new table TA17 LONDON. The legs and table top each have an impressive solid wood thickness of 60 mm which exude strength and modernity resulting in a pleasing and calm harmony of the proportions. TA17 LONDON by architect Philipp Mainzer takes up the design language of the 1995 classic. Compared to the BIGFOOT™ table, TA17 LONDON is designed without a frame and the cracks in the table's legs are filled, which add to the table's refined appearance. TA17 LONDON with its rectangular, length-wise positioned legs establishes its own powerful design language while preserving a graceful evolution of the classic TA04 BIGFOOT™.

ROUND DINING TABLE TA16 ANNA

In reference to the table TA14 ANTON e15 presents TA16 ANNA, the round version of the graceful table. Reduced to its essence in form and material, the round TA16 ANNA also designed by Philipp Mainzer, has a 20 mm thin table top in oiled oak, colour stained oak or oiled walnut and is available in two diameters. TA16 ANNA works as an elegant dining table that suits diverse interiors. With their thin diameter, the four table legs are fitted to the furthest possible engaged subframe underneath the table to offer the possibility of non-restrictive seating for up to six or eight places accordingly.

GLASS SIDE TABLE CT08 VIER

The glass table CT08 VIER is the latest side table from e15 and represents the consequential development of the glass side table CT07 DREI. Made from five coloured glass slabs joined together, the table designed by Philipp Mainzer extends the e15 range of side tables complementing the sofa system SF03 SHIRAZ. Due to its symmetric geometry, the table in dark blue or smoke grey solid coloured glass appears as a smart and stylish object which can serve as a side table, storage unit, bedside table or newspaper stand.

The new releases TA17 LONDON and CT08 VIER are nominated for the Interior Innovation Award 2010 of Koelnmesse.

CHAIR FAMILY CH04 HOUDINI

Following the successful launch of the chair CH04 HOUDINI in April 2009 in Milan, e15 now showcases the chair for the first time in Germany. For April 2010 e15 plans further items in the chair family by Munich based designer Stefan Diez and will present them at the Salone del Mobile in Milan.

The chair CH04 HOUDINI has been nominated for the following prestigious awards: the Red Dot Award 2010, the Interior Innovation Award 2010 of Koelnmesse and London Design Museum's Brit Insurance Design Awards 2010.

/ more...

SHELF SH05 ARIE

The shelf SH05 ARIE winner of the Red Dot Award 2009 and the Interior Innovation Award 2009 will be presented for the first time in a dismantlable version with an internal magnet construction that makes taking apart and putting together easy and connection points invisible. Designed by Paris based designer Arik Levy, the shelf, launched a year ago, is available in two heights and was until now delivered in one piece. The high version can now be delivered in two parts, which will make transportation of the product to the customer easier.

E15 STAND AT IMM COLOGNE

On the occasion of its anniversary, e15 exhibits at imm cologne 2010 with a new concept stand. The studio character of the stand, which also displays product models, material samples, furniture component parts, development images and drawings is intended to show the continual design process which the brand lives. The lighting with use of fluorescent tubes as well as the industrial floor emphasise e15's creative and work environment.

Notes to editors

After a creative period of 15 years, e15 now looks on having built a coherent collection of furniture, collaborations with artists, designers and architects from all over the world as well as an exclusive, international retailer network with over 550 partners. For its anniversary year the company plans a host of exhibitions and events worldwide.

The anniversary illustrations, which e15 uses on its stand, website and sales material are by New York based artist Mark Borthwick with whom e15 has collaborated previously on the exhibition and book 'Furnished Ways'.

E15 at IMM COLOGNE 2010

19. – 24. January 2010

Hall 11.2 Stand J20

Koelnmesse

Opening hours of the fair: 10.00 – 19.00 H

For further information and high resolution images please contact the e15 PR-Team: Susanne Günther, Tel. +49-(0)6171-9795 25, susanne.guenther@e15.com; Carina Müßen, Tel. +49-(0)6171-9795 23, carina.muessen@e15.com.

E15 Design und Distributions GmbH

www.e15.com

/ more...

COMMENCING ITS 15TH ANNIVERSARY E15 LAUNCHES THE FOLLOWING NEW PRODUCTS AT IMM COLOGNE 2010:

TA16 ANNA

Table

Design: Philipp Mainzer, 2009

In reference to the table TA14 ANTON e15 presents TA16 ANNA, the round version of the graceful table. Reduced to its essence in form and material, the round TA16 ANNA also designed by Philipp Mainzer, has a 20 mm thin table top in oiled oak, colour stained oak or oiled walnut and is available in two diameters. TA16 ANNA works as an elegant dining table that suits diverse interiors. With their thin diameter, the four table legs are fitted to the furthest possible engaged subframe underneath the table to offer the possibility of non-restrictive seating for up to six or eight places accordingly.

Material, Finish:

European oak, oiled; European walnut, oiled; European oak, stained, lacquered

Substructure:

Stainless steel, brushed; Steel, powdercoated

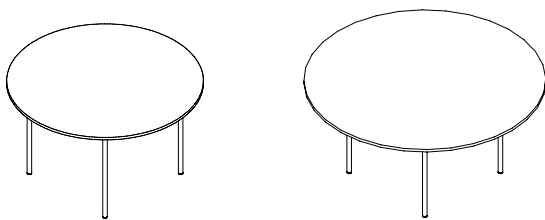

TA17 LONDON

Table

Design: Philipp Mainzer, 2009

Nominated for the Interior Innovation Award Cologne 2010.

As an evolution of the classic TA04 BIGFOOT™ e15 presents the new table TA17 LONDON. The legs and table top each have an impressive solid wood thickness of 60 mm which exude strength and modernity resulting in a pleasing and calm harmony of the proportions. TA17 LONDON by architect Philipp Mainzer takes up the design language of the 1995 classic. Compared to the BIGFOOT™ table, TA17 LONDON is designed without a frame and the cracks in the table's legs are filled, which add to the table's refined appearance. TA17 LONDON with its rectangular, length-wise positioned legs establishes its own powerful design language while preserving a graceful evolution of the classic TA04 BIGFOOT™.

Material, Finish:

European oak, oiled

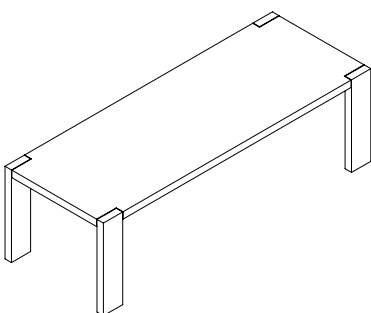

CT08 VIER

Side table

Design: Philipp Mainzer, 2009

Nominated for the Interior Innovation Award Cologne 2010.

The glass table CT08 VIER is the latest side table from e15 and represents the consequential development of the glass side table CT07 DREI. Made from five coloured glass slabs joined together, the table designed by Philipp Mainzer extends the e15 range of side tables complementing the sofa system SF03 SHIRAZ. Due to its symmetric geometry, the table in dark blue or smoke grey solid coloured glass appears as a smart and stylish object which can serve as a side table, storage unit, bedside table or newspaper stand.

Material, Finish:

Glass, solid coloured

Colours:

Dark blue; smoke grey

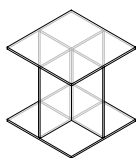

CH04 HOUDINI

Chair, Chair with armrest

Design: Stefan Diez, 2009

Nominated for the Interior Innovation Award Cologne 2010, Nominated for the Reddot Design Award 2010, nominated for the London Design Museum's Brit Insurance Design Awards 2010.

The side chair is part of the chair family CH04 HOUDINI developed by contemporary german designer Stefan Diez. Made from lacquered oak-veneered plywood the side chair has been designed to perfectly complement all e15 tables. Its unique design language and scale-like construction result in a modern yet timeless wooden chair that is ideal for contract and residential use. Its distinctive silhouette, creative use of material and production technique make the side chair an authentic e15 design object. The visually and physically light side chair features a curved backrest and 500 mm (19 3/5 inch) wide by 435 mm (17 1/8 inch) deep seat that ensures comfortable sitting. The seat height is 460 mm (18 1/9 inch). This chair is not stackable.

Material, Oberfläche:

Oak veneered plywood, clear lacquered; Oak veneered plywood, with colour lacquer; seat upholstered, completely upholstered

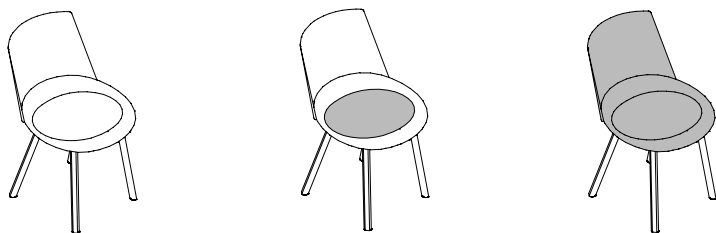

The chair with armrest from the chair family CH04 HOUDINI developed by contemporary German designer Stefan Diez, is made from lacquered oak-veneered plywood. Designed to perfectly complement all e15 tables, the chair's back and seat are constructed from oak-veneered plywood slabs stretched to harmoniously curve around a complexly milled solid wood base to form a comfortable seat shell. The visually and physically light CH04 HOUDINI features a front armrest height of 650 mm with a maximum height of 780 mm (30 3/5 inch) in the chair's back. The 570 mm (22 1/2 inch) wide by 400 mm (15 3/5 inch) deep seat ensures comfortable sitting. The seat height is 460 mm (18 1/9 inch). This chair is not stackable.

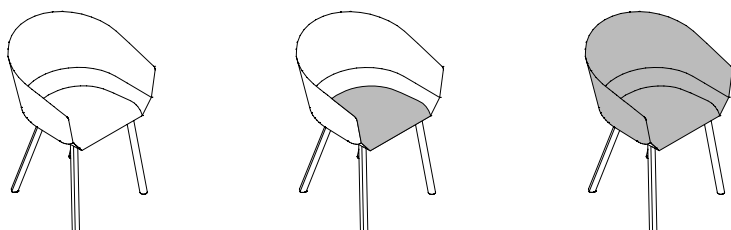

SH05 ARIE

Shelf

Design: Arik Levy, 2008

Winner of the Interior Innovation Award Cologne 2009., Winner of the Reddot Design Award 2009, Nominated for the Design Award of Federal Republic of Germany 2010.

The shelf SH05 ARIE is made of 25 mm thick solid wood or white powder-coated medium density fibreboard and is available in two different heights. The design concept makes a multitude of seamless combinations with itself possible without apparent visual repetitions. SH05 ARIE works either as a singular element, as shelving wall in a straight line, as an elegant corner solution with seamless docking points from both in and outside with its equal length and depth, or combination with the sideboard height. Invisible structural elements of the shelf enable it to be used as a freestanding room divider or as a traditional against-the-wall unit. This item is delivered in one piece. The high version can be delivered in two parts. The connector is magnetic and therefore invisible. The compartment height is 350 mm.

Available in 25 mm thick solid European oak, waxed or white powder-coated medium density fibreboard, SH05 ARIE is offered in a height of 1920 mm or as an alternative sideboard height of 795 mm.

