

E15 PRESS RELEASE

E15 IN HONG KONG DURING BODW 2011

SPECIAL E15 EXHIBITION AT DESIGNLINK, 29 NOVEMBER – 11 DECEMBER 2011

AT BODW, 01 – 03 DECEMBER 2011

E15 SHOWCASES NEW RELEASES 2011 AND CLASSIC E15 PRODUCTS BY DESIGNERS PHILIPP MAINZER, SASKIA DIEZ AND STEFAN DIEZ

Within the context of Business of Design Week Hong Kong (BODW) 2011, this year partnering with Germany, e15 showcases a selection of its new releases 2011 along with classic e15 pieces in a special exhibition at renowned modern furniture retailer Designlink, in addition to a distinct presence on the formally curated installation German Design Loft at BODW.

The special e15 exhibition at Designlink will include the debut of the new jewellery case AC02 JEWEL by Saskia Diez along with iconic e15 items such as the distinct and sculptural solid oak dining table TA17 LONDON, the bed SL05 PARDIS and the stool ST04 BACKENZAHN™, all by designer and e15 managing director Philipp Mainzer. The internationally awarded seating series by Stefan Diez for e15 including the chair CH04 HOUDINI and striking lounge chair EC03 EUGENE will also be on display at Designlink. The sumptuous tray CM05 HABIBI in brass, light LT02 SEAM TWO and awarded shelf SH05 ARIE are further highlights of the exhibition at Designlink.

At BODW and in the context of this year's theme "Brand New Germany", e15 has a distinct presence at German Design Loft, an exhibition of the German Design Council curated by recognised German architect Jürgen Mayer H. Debuting at BODW, the touring exhibition presents premium and luxury German brands from the sectors living, object and lifestyle. Selected as one of the few chosen brands, items on display from e15 include the iconic table TA04 BIGFOOT™, stool ST04 BACKENZAHN™ and chair CH04 HOUDINI.

Apparent in the sensuously refined, enduring furniture of e15 are the brand's principles of progressive design, high grade materials and innovative, handcrafted production methods. The exhibitions during BODW emphasise these principles displaying inspiring and diverse pieces that reflect e15's reduced and powerful design language.

Ends./

NOTES TO EDITORS

For further press information and high resolution images please contact the e15 in-house PR team:
Susanne Günther, Tel. +49-(0)6171-9795 25, susanne.guenther@e15.com; Rabea Reufsteck,
Tel. +49-(0)6171-9795 53, rabea.reufsteck@e15.com.

E15 Design und Distributions GmbH
www.e15.com

E15 AT DESIGNLINK

29.11. - 11.12.2011

Showroom Central
Ruttonjee Centre
11 Duddell Street
Central, Hong Kong
Phone +852 2868 0991

Opening hours:
Mon — Sat 10.00 — 19.00 H
closed on sundays and public holidays

E15 AT BODW

01. - 03.12.2011

More classic pieces by e15 at BODW on the
stand of German Design Loft

Booth No. 3D-C09
Hall 3D-3E
Hong Kong convention and exhibition centre
1 Expo Drive, Wanchai, Hong Kong

Press Preview: 01 Dec, 12.30 – 14.00 H
Company presentations for developers & architects:
01 Dec, 15.30 – 16.30 H

Reception: 01 Dec, 16.30 – 18.00 H

Opening hours:
01 – 03 December 2011
Thurs – Fri 09.30 – 19.00 H (Trade only)
Sat 09.30 – 18.30 H (Trade and public)

E15'S NEW RELEASES 2011 AND CLASSIC ITEMS FROM THE COLLECTION ON DISPLAY DURING BODW

AC02 JEWEL

JEWELLERY CASE

DESIGN: SASKIA DIEZ, 2011

The jewellery case AC02 JEWEL presents a special collaboration with the Munich designer Saskia Diez. From solid European walnut, the stackable, three-piece case extends the accessory range of e15. Each of the three shaped pieces has different interior partitions which lend itself beautifully to the storing of precious jewellery. The top sheath finishes with a closing top. The reduced design of AC02 JEWEL is in line with the aesthetics and design language of e15 and emphasises the used material.



EC03 EUGENE

LOUNGE CHAIR

DESIGN: STEFAN DIEZ, 2010

The lounge chair EC03 EUGENE makes an inspiring link to the chair family CH04 HOUDINI through its unique appearance and construction. With its high back, wide, deep seat shell and sloped back legs this generously proportioned lounge chair exudes lightness and leisure. Made from veneered lacquered plywood, EC03 EUGENE can be complemented with the seat and head cushions CU06 NIMA, CU09 EUGENE S and CU10 EUGENE H. Fixed upholstery of the seat is possible. Due to its round bent wooden back, EC03 EUGENE offers ample comfort also without padding. The stool ST11 DASH perfectly complements the lounge chair. Suited for private and public interiors, EC03 EUGENE is a versatile and unique item. Its seat height is 350 mm (13 7/8 inch), its seating depth 590 mm (23 1/4 inch) and seat width 590 mm (23 1/4 inch). EC03 EUGENE is delivered as one piece.

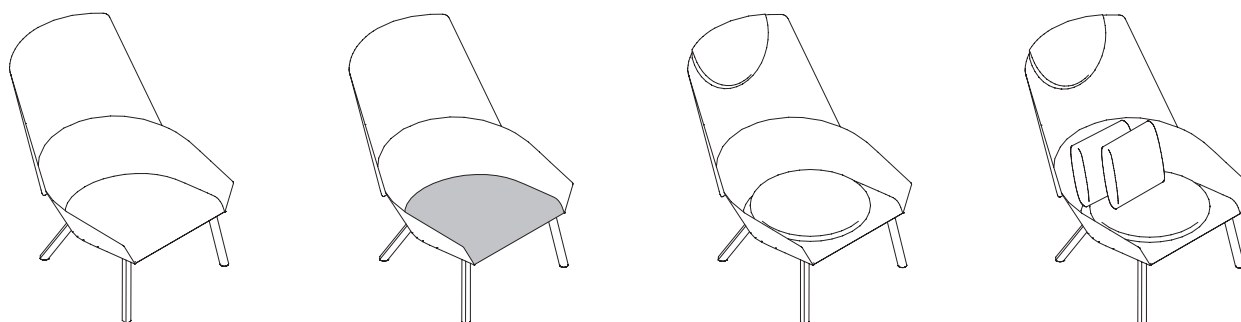

CH04 HOUDINI

CHAIR, CHAIR WITH ARMREST

DESIGN: STEFAN DIEZ, 2009

The side chair is part of the chair family CH04 HOUDINI developed by contemporary German designer Stefan Diez. Made from lacquered oak-veneered plywood the side chair has been designed to perfectly complement all e15 tables. Its unique design language and scale-like construction result in a modern yet timeless wooden chair that is ideal for contract and residential use. Its distinctive silhouette, creative use of material and production technique make the side chair an authentic e15 design object. The visually and physically light side chair features a curved backrest and 500 mm (19 3/5 inch) wide by 435 mm (17 1/8 inch) deep seat that ensures comfortable sitting. The seat height is 460 mm (18 1/9 inch). This chair is not stackable.

The chair with armrest from the chair family CH04 HOUDINI developed by contemporary German designer Stefan Diez, is made from lacquered oak-veneered plywood. Designed to perfectly complement all e15 tables, the chair's back and seat are constructed from oak-veneered plywood slabs stretched to harmoniously curve around a complexly milled solid wood base to form a comfortable seat shell. The visually and physically light CH04 HOUDINI features a front armrest height of 650 mm with a maximum height of 780 mm (30 3/5 inch) in the chair's back. The 570 mm (22 1/2 inch) wide by 400 mm (15 3/5 inch) deep seat ensures comfortable sitting. The seat height is 460 mm (18 1/9 inch). This chair is not stackable.



CH04 HOUDINI CONTRACT

CHAIR WITH ARMREST AND NEW CONTRACT UPHOLSTERY
DESIGN: STEFAN DIEZ, 2011

With particular focus on the contract market, e15 introduces five upholstered versions of the chair CH04 HOUDINI with armrest in oak-veneered plywood, lacquered. With optimised fabric purchasing and increased sums of the five fixed chair options, e15 can offer its CH04 HOUDINI CONTRACT as a less costly alternative. The upholstery of the seat and inside back along with the armrest upholstery in one fabric offer ample comfort and padding for CH04 HOUDINI whilst not entirely covering the chair's form and aesthetics. The upholstery and armrest padding respond to the special requirements of the contract market whilst also adding an artistic dimension to the chair. E15 offers its CH04 HOUDINI CONTRACT with armrest in upholstery combinations of contract proof Trevira CS, wool and cotton.

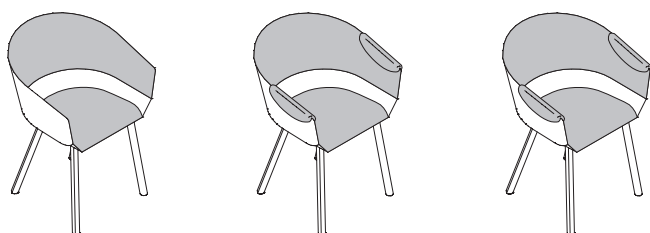

CH04 HOUDINI

CHAIR WITH ARMREST AND NEW UPHOLSTERY
DESIGN: STEFAN DIEZ, 2011

The visually and physically light chair with armrest is made from oak- or European walnut-veneered lacquered plywood. With its wide, comfortable seat shell it perfectly complements all e15 tables. CH04 HOUDINI with armrest is also available as part or fully upholstered versions, with the upholstery of the seat and inside back only as well as the special armrest upholstery offering ample comfort and padding. The upholstery is not removable. E15 offers its CH04 HOUDINI in upholstery combinations of Trevira CS, wool and cotton in addition to rich leather. As such, CH04 HOUDINI is ideally suited for private and public interiors. The 570 mm (22 1/2 inch) wide by 400 mm (15 5/8 inch) deep seat ensures comfortable sitting. The seat height is 460 mm (18 1/8 inch). This chair is not stackable and is delivered as one piece.

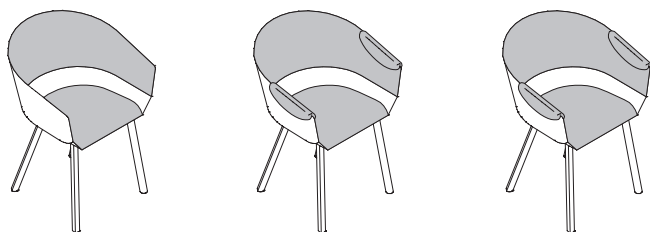

TA17 LONDON

TABLE

DESIGN: PHILIPP MAINZER, 2009

As an evolution of the classic TA04 BIGFOOT™ e15 presents the new table TA17 LONDON. The legs and table top each have an impressive solid wood thickness of 60 mm which exude strength and modernity resulting in a pleasing and calm harmony of the proportions. TA17 LONDON by architect Philipp Mainzer takes up the design language of the 1995 classic. Compared to the BIGFOOT™ table, TA17 LONDON is designed without a frame and the cracks in the table's legs are filled, which add to the table's refined appearance. TA17 LONDON with its rectangular, length-wise positioned legs establishes its own powerful design language while preserving a graceful evolution of the classic TA04 BIGFOOT™.

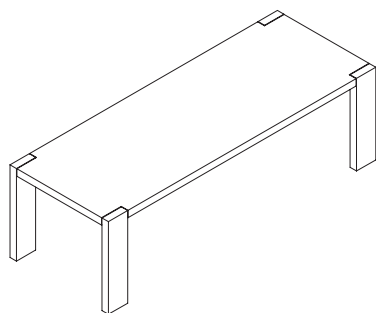

CU06 NIMA

CUSHION

DESIGN: E15, 2006

The accessory cushion CU06 NIMA has a soft cushioned filling which provides special seating comfort. It is available in six different dimensions. Through its versatile nature, the cushion CU06 NIMA perfectly complements the sofas SF02 KASHAN, SF03 SHIRAZ and SF05 BESS as well as the lounge chair EC02 BESSY, EC03 EUGENE and EC04 LEO.

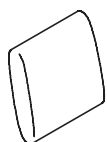

SL05 PARDIS

BED

DESIGN: PHILIPP MAINZER, 2007

The upholstered SL05 PARDIS bed is a natural extension of e15's SF03 SHIRAZ sofa. Like "Shiraz," the name "Pardis" is also Persian and means "paradise." In line with the Shiraz sofa series, the SL05 PARDIS bed eloquently combines elegant design, choice and functionality. The SL05 PARDIS is available in two different heights for the headrest and three separate widths. As an additional feature, the PARDIS headboard can also be ordered with a 450 mm (17 5/8 inch) extension on either the right or the left-hand side or alternatively extending on both sides of the frame. This extension of 450 mm (17 5/8 inch) results in a niche, where the bedside tables PA03 ALEX or PA05 LEILA can be positioned. The SL05 PARDIS bed is enhanced by individual modules of the SF03 SHIRAZ sofa series, which also provide additional seating and storage spaces. Fabric covers are removable. The bed SL05 PARDIS is suited for the private as well as contract market. SL05 PARDIS is also available with a frame height of 400 mm (15 3/4 inch).

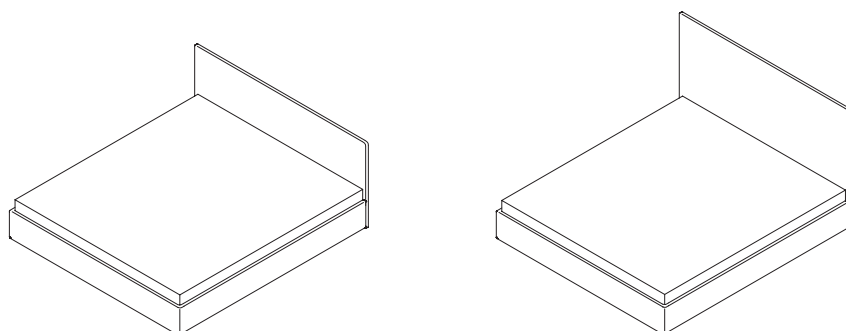

ST04 BACKENZAHN™

STOOL / SIDE TABLE

DESIGN: PHILIPP MAINZER, 1996

Considered a design classic, the ST04 BACKENZAHN™ has become an identifying icon for e15 and part of several permanent exhibitions in museums. With its four identical legs made of solid wood the stool makes a strong impression. The legs taper downward with two deliberate incisions. The gaps between the legs suggest that all four parts are still clearly recognisable, and the slightly concave seat provides seating comfort. ST04 BACKENZAHN™, available in solid oiled oak or oiled walnut, can also be supplied with a flat top to be used as a side table. Both as stool and side table ST04 BACKENZAHN™ is delivered as one piece

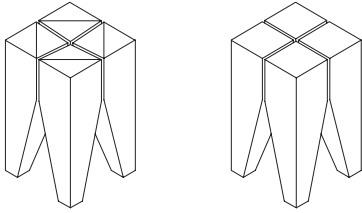

Ends. /